



# MACDILLIONS GLOBAL ENERGY

## CORPORATE PROFILE

# COMPANY OVERVIEW

Macdillions Global Energy is an exceptional company that offers a broad range of professional engineering consultation services, recruitment solutions, and innovative career training for companies and individuals seeking to make a breakthrough in the Oil and Gas, Manufacturing, Engineering, Automation, IT, and Aerospace industries.

They pride themselves on providing tailor-made services to our clients, which are all geared towards addressing their unique needs. They offer efficient and innovative recruitment and staffing services, enabling the bringing together of highly select experts and specialists from different fields and creating highly qualified integrated teams. The company's motto "the perfect engineers...anywhere," is essential to leverage the best practices, implement the best processes, build the right culture and formulate the perfect strategy for business transformation and expansion.

Their engineering consultations are centered on providing technical expertise per customer specifications, adapting to the toughest and most demanding performance requirements of our client's organization. They also specialize in providing outstanding solutions in engineering and design for manufacturing, automation systems, and various field needs within the industries they service.

Macdillions Global Energy has created a mark in the industry by offering unparalleled consultancy, recruitment, and career training services.



# VALUES

## SAFETY

As our top core value, we promote and nurture safety by making no compromises and implementing a zero tolerance policy for safety violations.

## INTEGRITY

We strive to demonstrate integrity by exhibiting trustworthiness, commitment and accountability.

## EXCELLENCE

We are committed to fostering a culture of excellence by surpassing standards of expectation, and constantly seeking methods of improvement.

# MISSION

We empower individuals and organizations by delivering innovative and sustainable solutions that drive growth, efficiency, and progress in the manufacturing and global energy sector.

# VISION

Our vision is to become the go-to and trusted partner for clients, providing them with exceptional talent and tailored solutions for their needs.



# CEO / FOUNDER



## COSMAS UFFORD

Cosmas Ufford is a visionary leader and the CEO / Founder of Macdillions Global Energy. With a background as a Mechanical Engineer, Cosmas brings invaluable expertise in industrial, electrical and automation engineering.

His passion for innovation and his commitment to excellence have positioned Macdillions Global Energy as a trusted partner to numerous clients worldwide. Under his guidance, the company has consistently delivered cutting-edge solutions, fostering growth and success in the industry.

His remarkable leadership has carved a path of success, making Macdillions Global Energy a force to be reckoned with in the Oil and Gas sector.



# OUR SERVICES AT A GLANCE



## ENGINEERING CONSULTANCY

We strive to provide top-notch engineering solutions to our clients. Our team of highly-skilled and experienced engineers tackle projects of varying complexity and scale.



## RECRUITMENT & STAFFING

Our team of skilled recruiters are experienced in sourcing, screening, and hiring top-quality candidates across various industries.



## CAREER TRAINING

Our company is a leader in providing engineering & technical career training services to individuals and organizations seeking to develop their skills and knowledge.



## GENERAL CONTRACTS & SUPPLY

We supply oil tools, electrical control panels, subsea tools and equipments such as ROVs.



# INSTALLATION, ALIGNMENT AND MAINTENANCE SERVICES



## FLANGE MANAGEMENT

We offer comprehensive flange management services. Our expert team ensures proper installation, inspection, and maintenance of flanges, minimizing leaks, enhancing safety, and optimizing operational efficiency.



## LASER ALIGNMENT

We specialize in providing precise alignment services for pumps and motors. Our skilled technicians use advanced laser technology to accurately measure and correct misalignments, ensuring optimal performance, reducing wear and tear, and maximizing efficiency.



## LEVELLING

We deliver top-tier precision installation services powered by advanced leveling tools. Our expert team ensures accurate and reliable equipment installation, guaranteeing optimal performance and longevity.

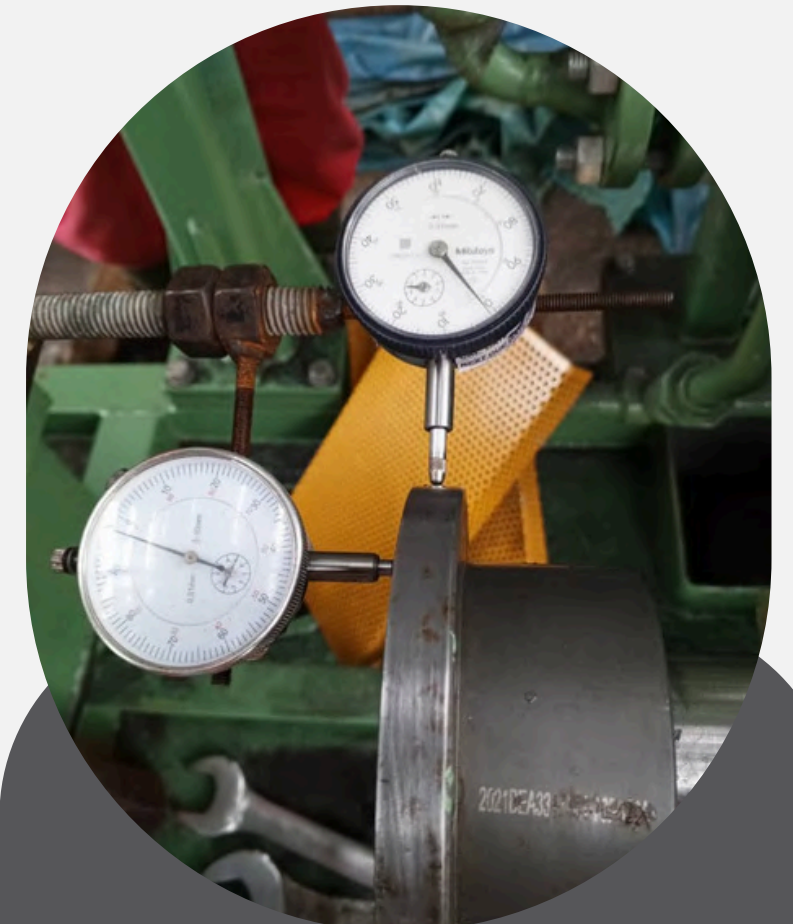

## RIM AND FACE ALIGNMENT

We utilize the rim and face alignment method to ensure precise positioning and alignment of components. This method involves aligning the rim and face of different parts, optimizing performance, and minimizing energy loss, and is a reliable technique that enhances efficiency and promotes smooth operation in the energy sector.



# WHY CHOOSE US?



**PROFESSIONAL**  
WORKING EXPERIENCE

**DEDICATED**  
EXPERIENCED EMPLOYEES

**QUALITY**  
DELIVERABLES



**MGE MACDILLIONS GLOBAL ENERGY**

**WHAT WE DO**

**ENGINEERING CONSULTANCY**

- Engineering & consultancy services in mechanical, electrical, and automation
- Wide range of industries in engineering sectors: oil & gas, manufacturing, information technology & maintenance

**RECRUITMENT AND STAFFING**

- Source, screen & hire top-quality candidates across various industries
- Conduct thorough background checks and pre-employment tests
- Offer consultation on HR matters, such as employee retention and development

**CAREER TRAINING**

- Engineering design & analysis





# BUSINESS STRATEGY: **SERVICE OFFERINGS**

## **ENGINEERING CONSULTANCY**

Provide comprehensive engineering consultancy services, including feasibility studies, project management, design and engineering, risk assessment, and quality control. Develop a team of experienced engineers and subject matter experts to deliver high-quality solutions to clients.

## **RECRUITMENT AND STAFFING**

Build a strong network of industry professionals and develop a robust recruitment and staffing process. Offer tailored staffing solutions to clients, including permanent placements, contract staffing, and executive search services. Focus on attracting and retaining top talent in the industry.

## **CAREER TRAINING**

Develop a range of career training programs to enhance the skills and knowledge of professionals in the Oil and Gas industry. Offer both technical and soft skills training, including industry-specific certifications, leadership development programs, and specialized workshops.



# BUSINESS STRATEGY: MARKET ANALYSIS

## IDENTIFY TARGET MARKET

Conduct thorough market research to identify the specific segments within the Oil and Gas industry that require engineering consultancy, recruitment and staffing, and career training services. This may include upstream, midstream, and downstream sectors, as well as specific regions or countries.

## COMPETITIVE ANALYSIS

Analyze the competition in the market to identify their strengths, weaknesses, and unique selling propositions. This will help us differentiate ourselves and develop strategies to gain a competitive advantage.

## INDUSTRY TRENDS

Stay updated with the latest industry trends, technological advancements, and regulatory changes. This will enable us to adapt our services and offerings accordingly and stay ahead of the curve.

# BUSINESS STRATEGY: **MARKETING & BRANDING**

## **BRAND POSITIONING**

Develop a strong brand identity that reflects our expertise, reliability, and commitment to excellence. Position ourselves as a trusted partner for clients, a preferred employer for professionals, and a leading provider of career development opportunities.

## **MARKETING CHANNELS**

Utilize a mix of traditional and digital marketing channels to reach our target audience. This may include industry conferences and events, online advertising, social media marketing, content marketing, and search engine optimization.

## **CLIENT RELATIONSHIP MANAGEMENT**

Build strong relationships with existing clients and focus on client retention. Offer personalized solutions, maintain regular communication, and provide exceptional customer service. Leverage client testimonials and referrals to attract new clients.



# THE PROCESS

## CLIENT ACQUISITION PROCESS

**IDENTIFY POTENTIAL CLIENTS.** Conduct market research and identify potential clients in the Oil & Gas industry who are in need of engineering consultancy, recruitment & staffing, or career training services.

**LEAD GENERATION.** Utilize various marketing channels, such as industry events, online advertising, and referrals, to generate leads and attract potential clients.

**NEEDS ASSESSMENT.** Engage with potential clients to understand their specific needs and requirements. Conduct meetings, presentations, and discussions to gather information and assess how our services can add value to their business.

**PROPOSAL DEVELOPMENT.** Develop customized proposals outlining the scope of work, deliverables, timelines, and pricing. Ensure that the proposals align with the client's requirements and address their pain points effectively.

**NEGOTIATION AND CONTRACTING.** Engage in negotiations with the client to finalize the terms and conditions of the engagement. Once an agreement is reached, prepare and sign contracts to formalize the partnership.

# THE PROCESS

## ENGINEERING CONSULTANCY PROCESS

**PROJECT SCOPING.** Collaborate with the client to define the project objectives, scope, and deliverables. Conduct site visits, gather relevant data, and analyze requirements to develop a comprehensive project plan.

**DESIGN AND ENGINEERING.** Assign a team of experienced engineers and subject matter experts to develop detailed designs, engineering calculations, and technical specifications. Ensure compliance with industry standards and regulations.

**PROJECT MANAGEMENT.** Establish project milestones, timelines, and budgets. Monitor the progress of the project, manage resources effectively, and address any issues or risks that may arise. Maintain regular communication with the client to provide updates and seek feedback.

**QUALITY CONTROL.** Implement a robust quality control process to ensure that the project deliverables meet the required standards. Conduct regular inspections, tests, and audits to identify and rectify any deviations or deficiencies.

**COMMISSIONING / PROJECT HANDOVER.** Upon completion of the project, conduct a thorough handover process to transfer the deliverables to the client. Provide necessary documentation, training, and support to ensure a smooth transition.



# THE PROCESS

## RECRUITMENT & STAFFING PROCESS

**JOB REQUIREMENT ANALYSIS.** Collaborate with the client to understand their staffing needs, including job descriptions, qualifications, and experience requirements.

**SOURCING AND SCREENING.** Utilize various recruitment channels, such as job portals, social media, and professional networks, to source potential candidates. Screen resumes, conduct initial interviews, and shortlist candidates based on their suitability for the role.

**CANDIDATE EVALUATION.** Conduct in-depth interviews, technical assessments, and check references.

**ACADEMIC RECORD SCREENING.** Conduct academic record screening on potential candidates after the interviews.

**BACKGROUND AND DRUG SCREENING.** Conduct background and drug screening for potential candidates before onboarding.

**SEND CANDIDATE TO CLIENT.** Once candidates pass through our screening process, hand them over to the client for further interviews or testing as the client desires.



# BUSINESS ANALYTICS

## JOB PLACEMENT SUCCESS RATE

Percentage of job seekers who have been successfully placed in positions by Macdillions Global Energy.

## CLIENT SATISFACTION RATE

Percentage of clients who are satisfied with the services provided by Macdillions Global Energy.

## REVENUE GROWTH RATE

Percentage increase in revenue over a specific period, such as quarterly or annually.

## EMPLOYEE RETENTION RATE

Percentage of employees who remained with Macdillions Global Energy over a given period.

## TRAINING PROGRAM COMPLETION RATE

percentage of individuals who successfully completed career training programs offered by Macdillions Global Energy.

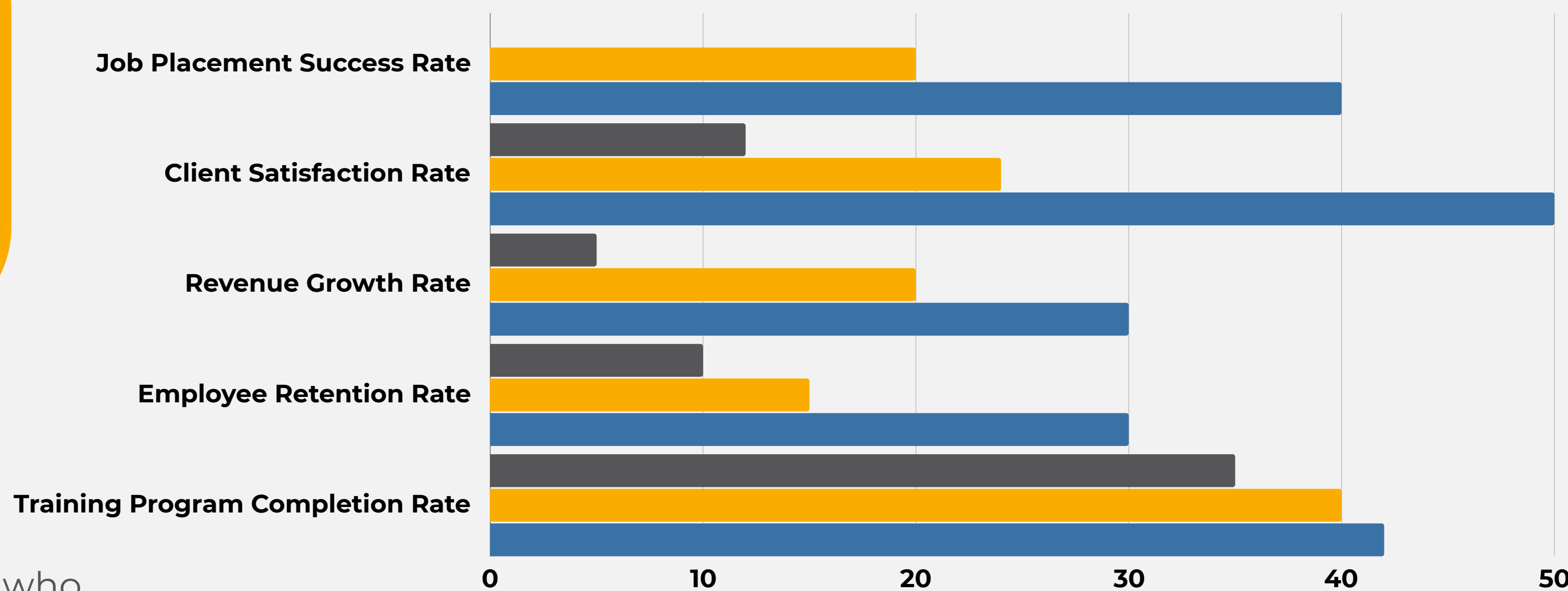



# PORT HARCOURT REFINERY REHABILITATION PROJECT





# PUMP & MOTOR ALIGNMENT

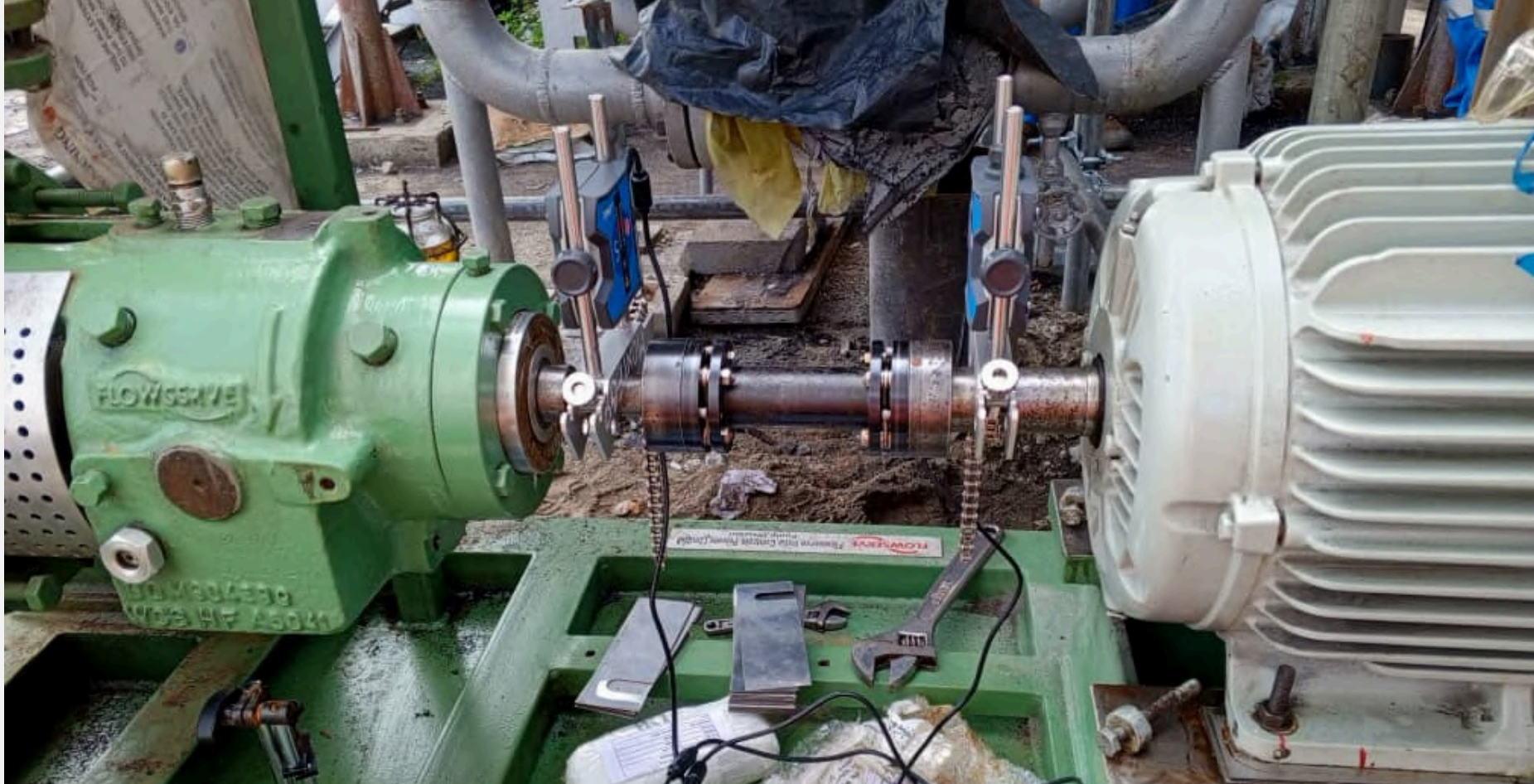





# EQUIPMENTS & TOOLS









# ULTRA-BAR 30DS HYDROBLAST UNIT



## EFCO VALVE TEST BENCH EQUIPMENT





# EFCO VALVE TEST BENCH EQUIPMENT





**TOOL  
ALIGNMENTS**

**LASER**



SKF TKSA 31 Basic Wired Laser Shaft Alignment Tool



SKF TKSA 41 Wireless Laser Shaft Alignment Tool







# LEVELLING TOOLS



Dasqua 150mm 200mm 250mm 300mm Graduation 0.02 Bar Level Meter Spirit Level Master Precision Level Measuring Tool



Dasqua High Precision 150mm 200mm 250mm 300mm Master Mechanical Bar Level Meter Mechanic Spirit level Instrument Measurement





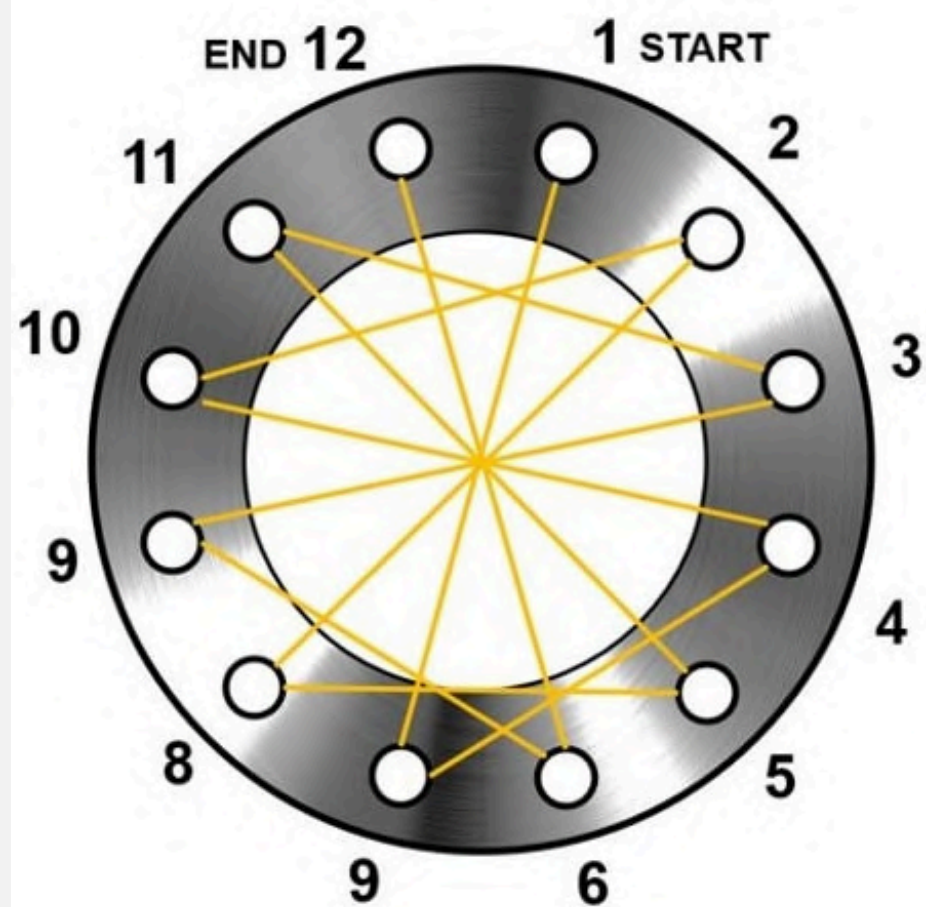
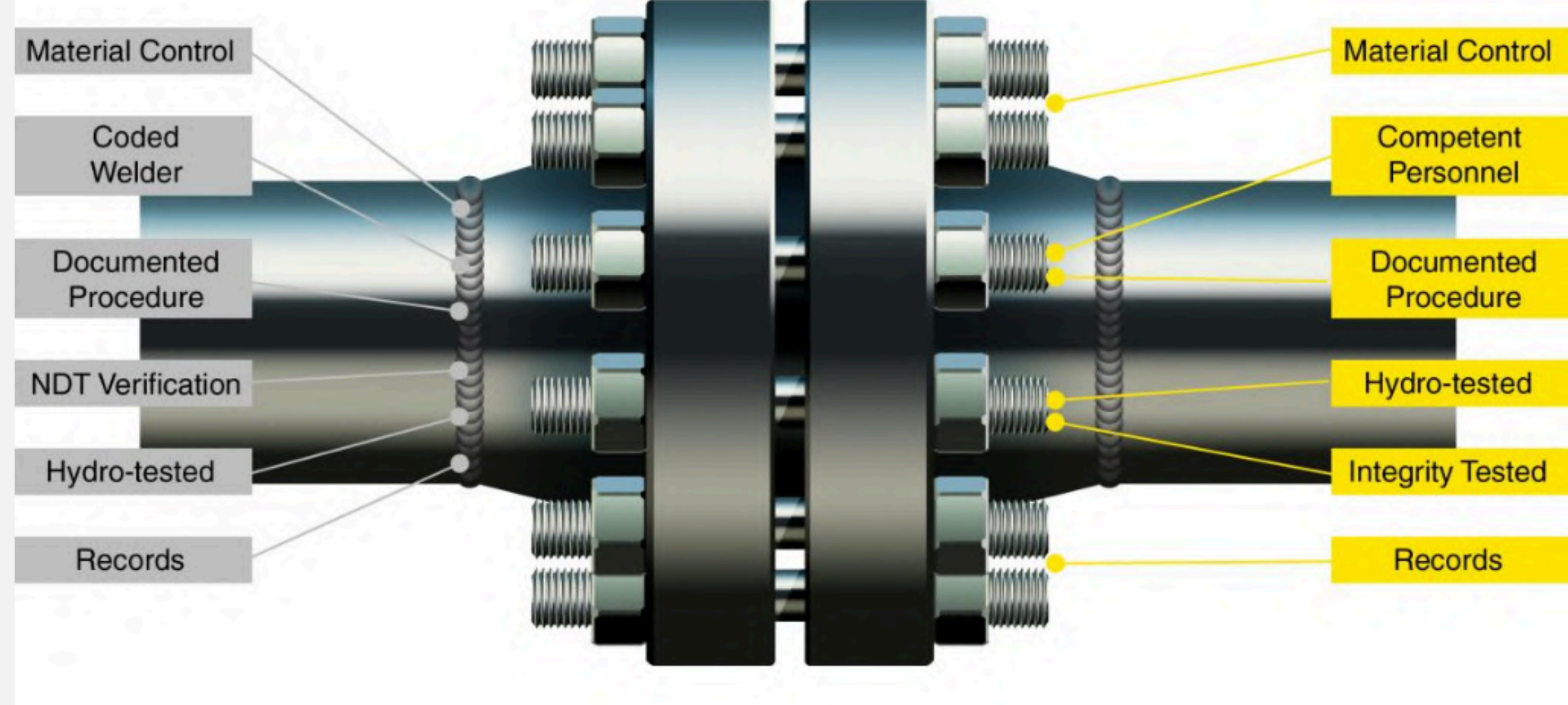

Fig 1 Legacy Numbering Pattern

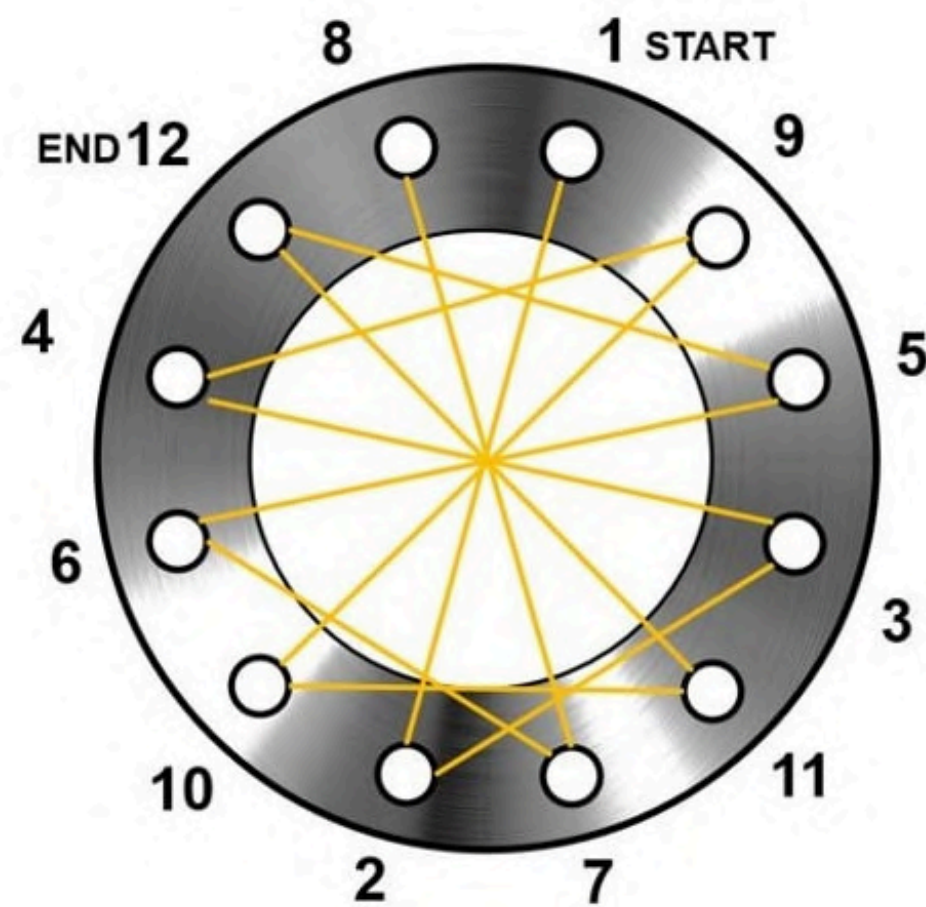

Fig 2 Alternative to Legacy Numbering





Flange Register x Workpack Register x Drawing Register x ISO-XX-ERW-001 (View) x PID 2 - FRA-P40052-PC-PID-003\_09 (View) x

Activity Log

Flange Added	
Flange Spec Added	
Flange Modified	
Disassemble	22/07/2015
Assemble	22/07/2015
Torque	22/07/2015
Disassemble	22/07/2015 A

Logged by User: Campbell-Laptop/Campbell

Technician: Ian Brown  
Technician: Jim Thomas  
Disassembly Method: Torque  
Anomaly: No  
Comments:

Integrus

File Edit View Database Reports Help

Flange Register x Workpack Register x Drawing Register x ISO-XX-ERW-001 (View) x PID 2 - FRA-P40052-PC-PID-003\_09 (View) x

Date: 10/11/2016 Technician: Ian Brown Technician: Jim Thomas  
Disassembly Method: Torque  
Anomaly: No

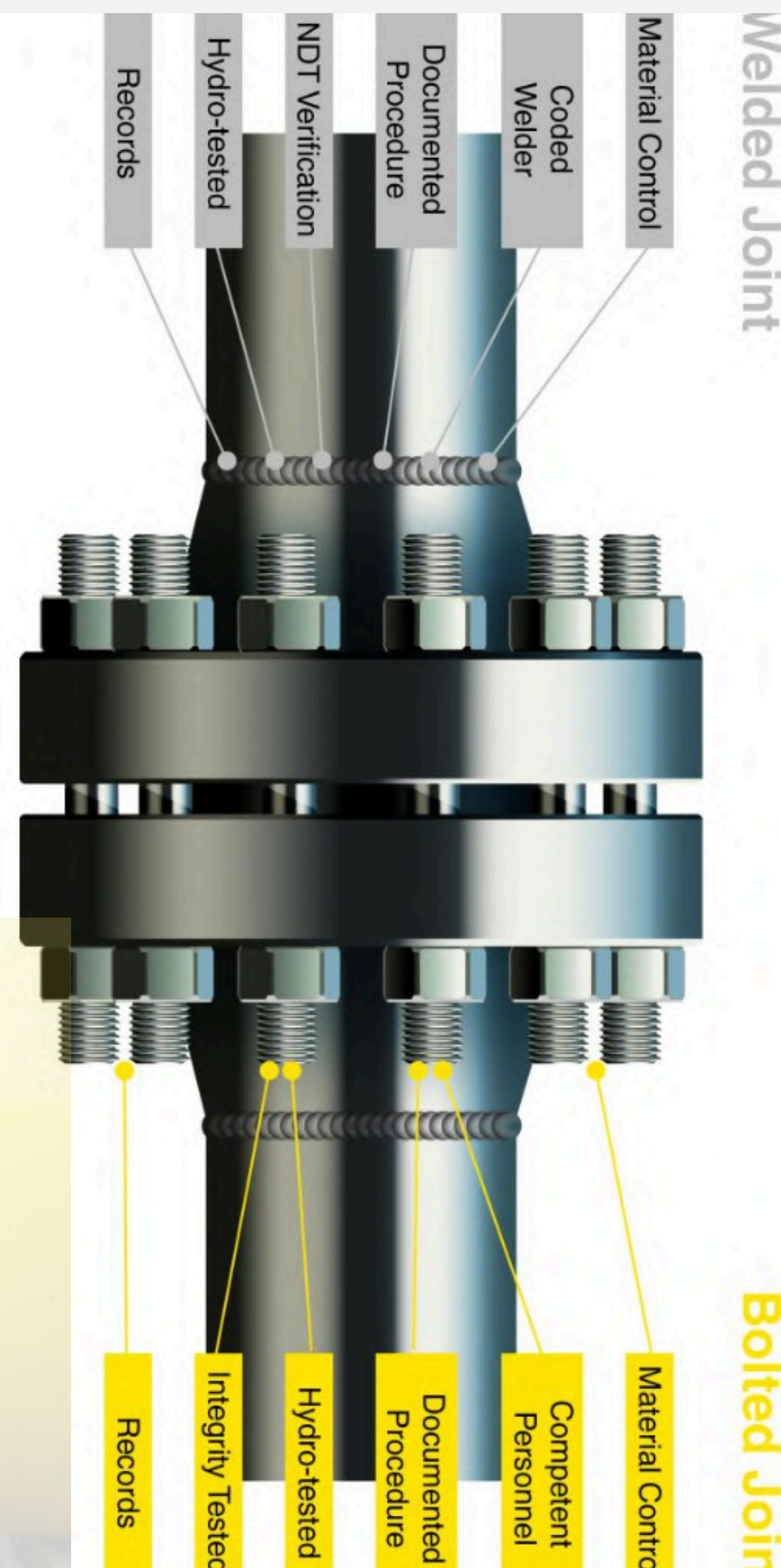



# OUR PARTNERS





# LET'S CONNECT



+1 770 568 5125  
+234 811 556 6989



+1 770 576 1933



[www.macdillionsge.com](http://www.macdillionsge.com)



[info@macdillionsge.com](mailto:info@macdillionsge.com)



## USA

Macdillions Global Energy  
P.O. Box 625,  
Ball Ground, Georgia, 30107, USA

## Africa Operational Base

Macdillions Global Energy  
Chesroc Complex  
236 Lyowuna Drive,  
Off Peter Odili Road, Trans Amadi,  
Port Harcourt, Rivers State, Nigeria

